



Fishing

Merit Badge Workbook

This workbook is not required but is designed to help you with this merit badge. No one can add or subtract from the Boy Scout Requirements #33215. Use page backs & add pages as needed. Please send comments to: craig@craiglincoln.com. Requirements revised: 2002, Workbook updated: January 2004.

Scout's Name: _____ Unit: _____

Counselor's Name: _____ Counselor's Ph #: _____

1) Explain to your counselor the injuries that could occur while fishing and the proper treatment, including

- cuts, _____
- scratches, _____
- puncture wounds, _____
- insect bites, _____
- hypothermia, _____
- dehydration, _____
- and heat reactions. _____

Explain how to remove a hook that has lodged in your arm. _____

Name and explain five safety practices you should always follow while fishing.

- 1) _____
- 2) _____
- 3) _____
- 4) _____
- 5) _____

2) Learn and explain the differences between two types of fishing outfits. Type 1: _____

Type 2: _____ Differences: _____

Point out and identify the parts of several types of rods and reels. Explain how and when each would be used. Review with your counselor how to care for this equipment. (Hint: Consider the rod and reels listed below or others.)

Saltwater Reel



Bait-casting Reel

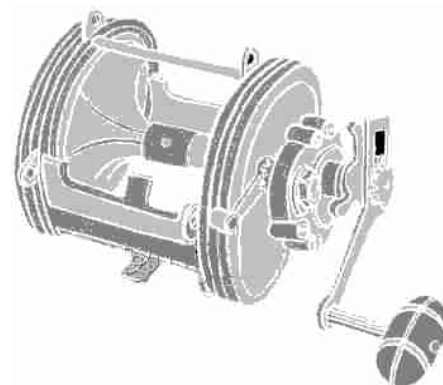

How used: _____

When used: _____

Care: _____

Spinning Rod & Reel

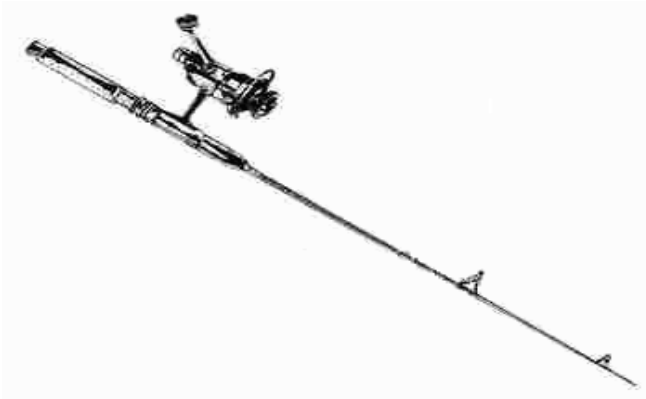

How used: _____

When used: _____

Care: _____

Fly Fishing Rod & Reel



Fishing Rods



Care: _____

3) **Demonstrate** the proper use of two different types of fishing equipment.

4) **Demonstrate** how to tie the following knots: clinch, palomar, turle, blood loop (barrel knot), and the surgeon's loop. Explain how each knot is used and when to use it.

clinch, _____

palomar, _____

turle, _____

blood loop (barrel knot), _____

and the surgeon's loop. _____

5) Name and Identify five Artificial Lures and explain how to fish with them:

1) _____

2) _____

3) _____

4) _____

5) _____

Name and Identify five Natural Baits and explain how to fish with them:

1) _____

2) _____

3) _____

4) _____

5) _____

Explain why baitfish are not to be released. _____

6) Explain the importance of practicing Leave No Trace and how it positively affects fishing resources. _____

7) Give the regulations affecting game fishing where you live. Explain why they were adopted and what you accomplish by following these regulations.

8) Explain what good outdoor sportsmanlike behavior is and how it relates to fishermen. _____

Tell how the Outdoor Code of the Boy Scouts of America relates to a fishing sports enthusiast, including the aspects of littering, _____

trespassing, _____

courteous behavior, _____

and obeying fishing regulations. _____

9) **Catch two different kinds of fish and identify them.**

Release at least one of them unharmed.

Clean and cook another fish.